

SA-H112
Drives Mounting Chassis
Manual

SA-H112
Drives Mounting Chassis
Manual

Copyright © Sigma Information Systems
Anaheim, CA - May, 1983

CONTENTS

SECTION 1 - GENERAL INFORMATION

| | | |
|-----|---------------------|-----|
| 1.1 | INTRODUCTION | 1-1 |
| 1.2 | GENERAL DESCRIPTION | 1-1 |
| 1.3 | SPECIFICATIONS | 1-2 |

SECTION 2 - INSTALLATION

| | | |
|-----|--------------------------------------|-----|
| 2.1 | UNPACKING AND INSPECTION | 2-1 |
| 2.2 | POWER CHECKOUT | 2-2 |
| | 2.2.1 DC Power | 2-2 |
| | 2.2.2 AC Power | 2-3 |
| 2.3 | 8" DEVICE INSTALLATION | 2-3 |
| | 2.3.1 Dual 8" Slimline Floppy Drives | 2-3 |
| | 2.3.2 Other 8" Device Installation | 2-4 |
| 2.4 | WINCHESTER DRIVE INSTALLATION | 2-5 |

| | | |
|--|-----------------------------------|-----|
| | APPENDIX - POWER SUPPLY SCHEMATIC | A-1 |
|--|-----------------------------------|-----|

FIGURES

| | | |
|-----|-------------------------------|-----|
| 1-1 | SA-H112 Example Configuration | 1-2 |
| 2-1 | DC Power Connectors | 2-2 |
| 2-2 | AC Power Configuration | 2-3 |
| 2-3 | Floppy Drives Installation | 2-4 |
| 2-4 | Winchester Drive Installation | 2-6 |

Section 1 - General Information

1.1 INTRODUCTION

This manual provides the information necessary to install and cable drives in the SA-H112 chassis manufactured by Sigma Information Systems, Anaheim California. The material in this manual is arranged in the following sections:

Section 1 - GENERAL INFORMATION. This section contains a brief description of the SA-H112. Specifications are included.

Section 2 - INSTALLATION. This section explains the procedures for installing drives into the SA-H112 chassis. Cabling information is included.

APPENDIX. The appendix contains the power supply schematic for troubleshooting.

1.2 GENERAL DESCRIPTION

The SA-H112 expansion chassis is designed for mounting either two 5 1/4" winchester drives or one 5 1/4" winchester drive and an 8" device. The chassis supports 8" devices such as a standard floppy drive, a tape cartridge transport, or two slimline floppy drives.

The chassis is available in a tabletop version or a rackmount version that installs in a standard 19" RETMA-type rack and occupies only 5.25 inches of vertical rack space.

The SA-H112 includes a dependable power supply, cooling fan, rear AC power switch and a front bezel with 8" device access. The power supply AC inputs are 115/230VAC jumper configurable.

Figure 1-1 is an example configuration of the SA-H112.

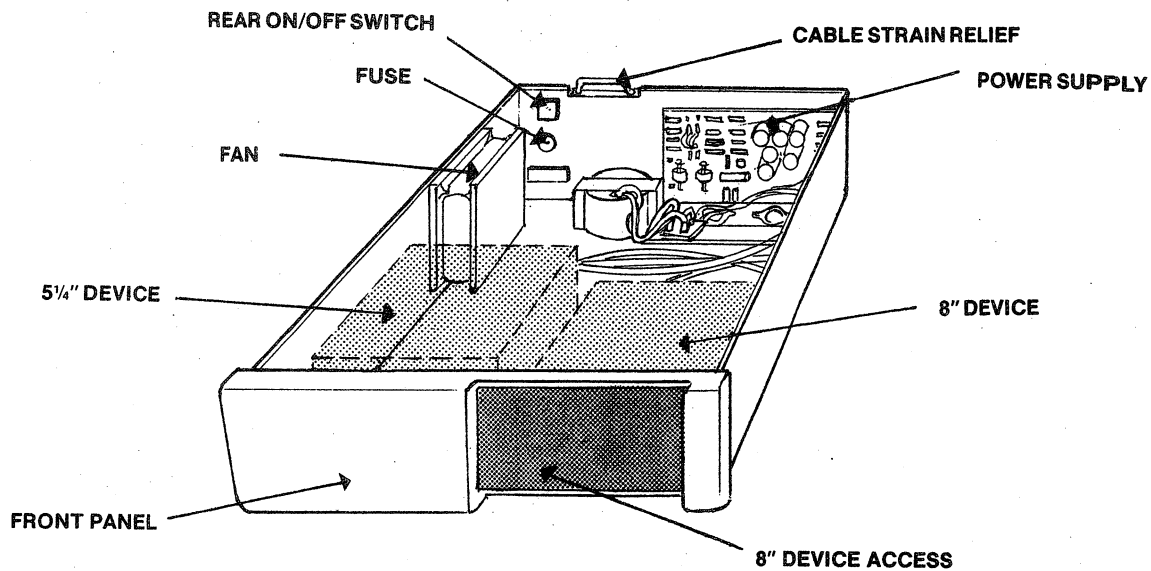

FIGURE 1-1: SA-H112 EXAMPLE CONFIGURATION

1.3 SPECIFICATIONS

| | |
|--|--|
| <p>Installation: Tabletop version or rack-mount version that mounts in standard 19" wide RETMA-type rack and occupies 5.25" of vertical rack space.</p> | <p>Cable Egress: At rear of chassis with cable strain relief bar</p> |
| <p>Dimensions: 20"D x 5.25"H x 19"W</p> | <p>Temperature Operating: 0°C to 50°C Storage: -45°C to 85°C</p> |
| <p>Power Supply AC Input: Jumper configurable 115/230VAC, 50/60Hz, 275 VA maximum</p> | <p>Humidity: 0% to 95% noncondensing</p> |
| <p>DC Output: +5V @ 6A, -5V @ 0.5A, +12V @ 5A and +24V @ 2A</p> | <p>Altitude Operating: 0 ft to 10,000 ft Storage: 0 ft to 30,000 ft</p> |
| | <p>Cooling: Forced air intake with right side exhaust</p> |

Section 2 - Installation

2.1 UNPACKING AND INSPECTION

The SA-H112 is shipped in a specially designed carton for protection against abrasion and vibration. Retain the carton in case reshipment is necessary.

Unpack the chassis and visually inspect it for damage that might have occurred during shipment. If any damage has occurred, notify Sigma Information Systems immediately. Verify that the carton contains the following standard items:

SA-H112 5.25" chassis with power supply, drive mounting rails, and front panel.

Hardware kit containing required hardware for rackmounting chassis into 19" RETMA-type rack (rackmount versions only).

AC power cord and manual.

The following items are optional, based on configuration specified at time of order:

Mounting brackets and hardware for dual slimline floppy drives.

Winchester formatter mounting assembly with metal bracket, insulating spacers, mylar insulator, and associated hardware.

Front access bracket and hardware for tape cartridge transport.

34-conductor and 20-conductor formatter/winchester drive ribbon cables.

50-conductor ribbon cables for winchester controller/formatter and floppy controller/drive connections.

2.2 POWER CHECKOUT

2.2.1 DC Power

Before installing the drives, verify correct DC power at the cable connectors or from the power control module. The cable connectors are illustrated and voltages are defined in Figure 2-1 below.

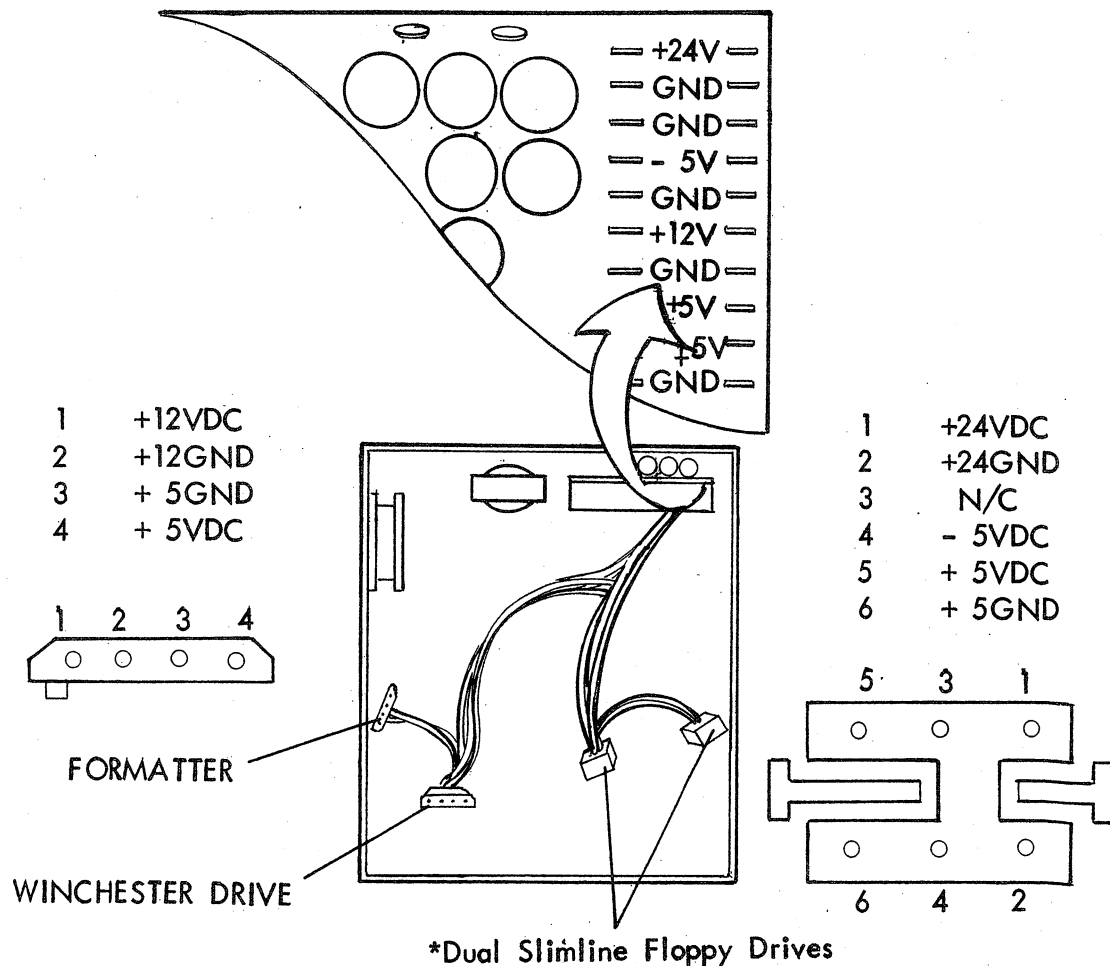

FIGURE 2-1: DC POWER CONNECTORS

2.2.2 AC Power

The AC power is preset upon order. To verify correct AC configuration, or to convert between 115VAC and 230VAC, refer to Figure 2-2.

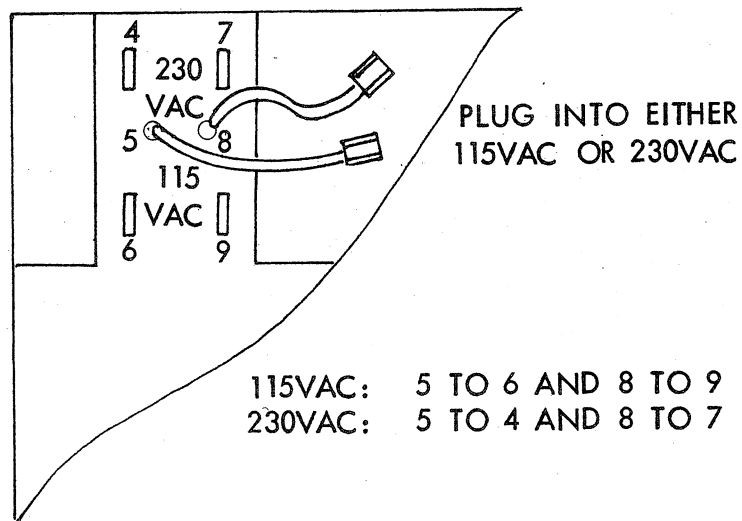

FIGURE 2-2: AC POWER CONFIGURATION

2.3 8" DEVICE INSTALLATION

2.3.1 Dual 8" Slimline Floppy Drive Installation

The following procedure is an example of floppy drives installation using Tandem 848-2 slimline drives. Other hardware compatible drives can be installed in a similar manner. If drive manufacturer configurations differ greatly from this procedure consult Sigma Information Systems for installation procedure.

1. Using Figure 2-3 as a guide, install two mounting brackets on each side of the drives using #6-32 flathead screws.

2. Place the drives on the mounting bars (right side of chassis) and secure from the bottom mounting holes using #8-32 panhead screws.
3. Using Figure 2-1 as a guide, connect the proper power cables to the power connectors.

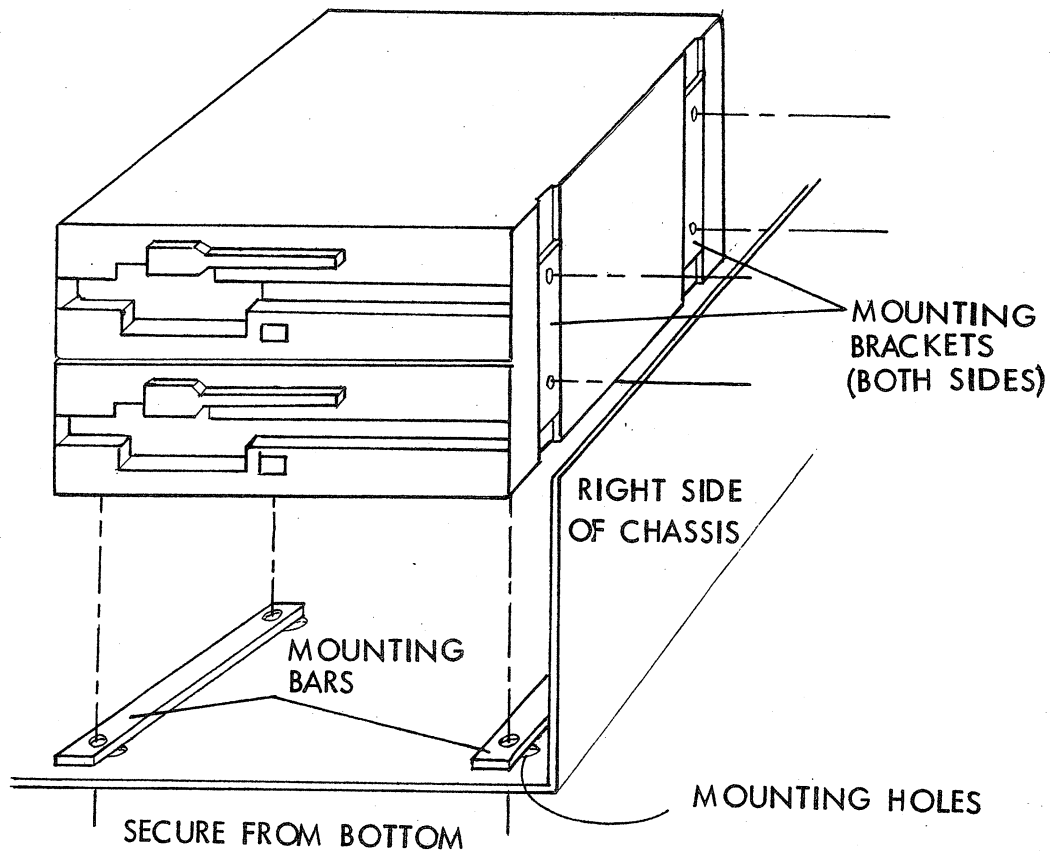

FIGURE 2-3: FLOPPY DRIVES INSTALLATION

2.3.2 Other 8" Device Installation

When installing other 8" devices such as a standard floppy drive or tape cartridge transport, place the device on the mounting bars shown in Figure 2-3 and secure from the bottom mounting holes using #8-32 panhead screws. Using Figure 2-1 as a guide, connect the proper power cables to the power connectors.

2.4 WINCHESTER DRIVE INSTALLATION

Using Figure 2-4 as a guide, perform the following procedure to install the winchester drive and formatter module.

1. Place the mylar sheet inside the formatter mounting bracket.
2. Place the formatter module inside mounting bracket with the solder side of the formatter facing the mylar sheet.
3. Position nylon spacers between mylar sheet and formatter module and secure the module to the mounting bracket using four nylon screws.

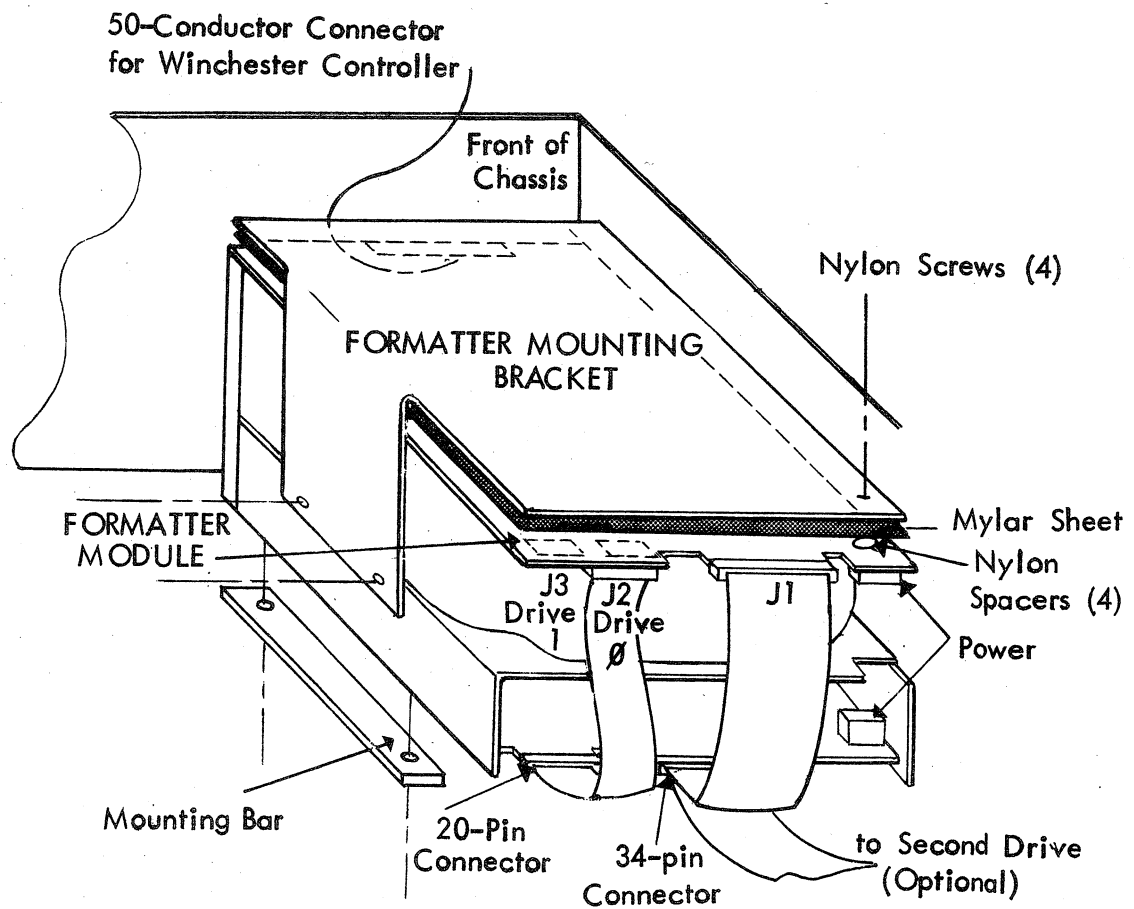

FIGURE 2-4: WINCHESTER DRIVE INSTALLATION

4. Place formatter assembly over winchester drive and secure the assembly to the drive sides using four 6-32 x 3/8 screws.
5. Place the drive assembly on the mounting bars (left side of chassis as viewed from the front) and secure from bottom mounting holes using #6-32 x 3/8 panhead screws.
6. Connect the 20-pin and 34-pin ribbon cables from the drive to the formatter as shown.
7. Using Figure 2-1 as a guide, connect the proper power cables to the power connectors.

If a second winchester drive is to be installed, continue with the following procedure.

8. Place the second drive over the mounting bars shown in Figure 2-3 and secure from the bottom using #6-32 x 3/8 panhead screws.
9. Remove termination resistor module from second drive and set drive selection jumpers for second drive.
10. Extend the 34-pin J1 formatter cable from the first drive (drive 0) to the 34-pin edge connector on the second drive (drive 1)
11. Connect a 20-pin ribbon cable from J3 on the formatter module to the 20-pin edge connector on the second drive.
12. Using Figure 2-1 as a guide, connect the proper power cables to the power connectors.

After the winchester drive(s) are installed, format the new drive, write the bad sector file and, when possible, run diagnostics on the drive(s) before using.

| ZONE | REV. | DESCRIPTION | DATE | APPROVED |
|------|------|-------------|------|----------|
| | | | | |

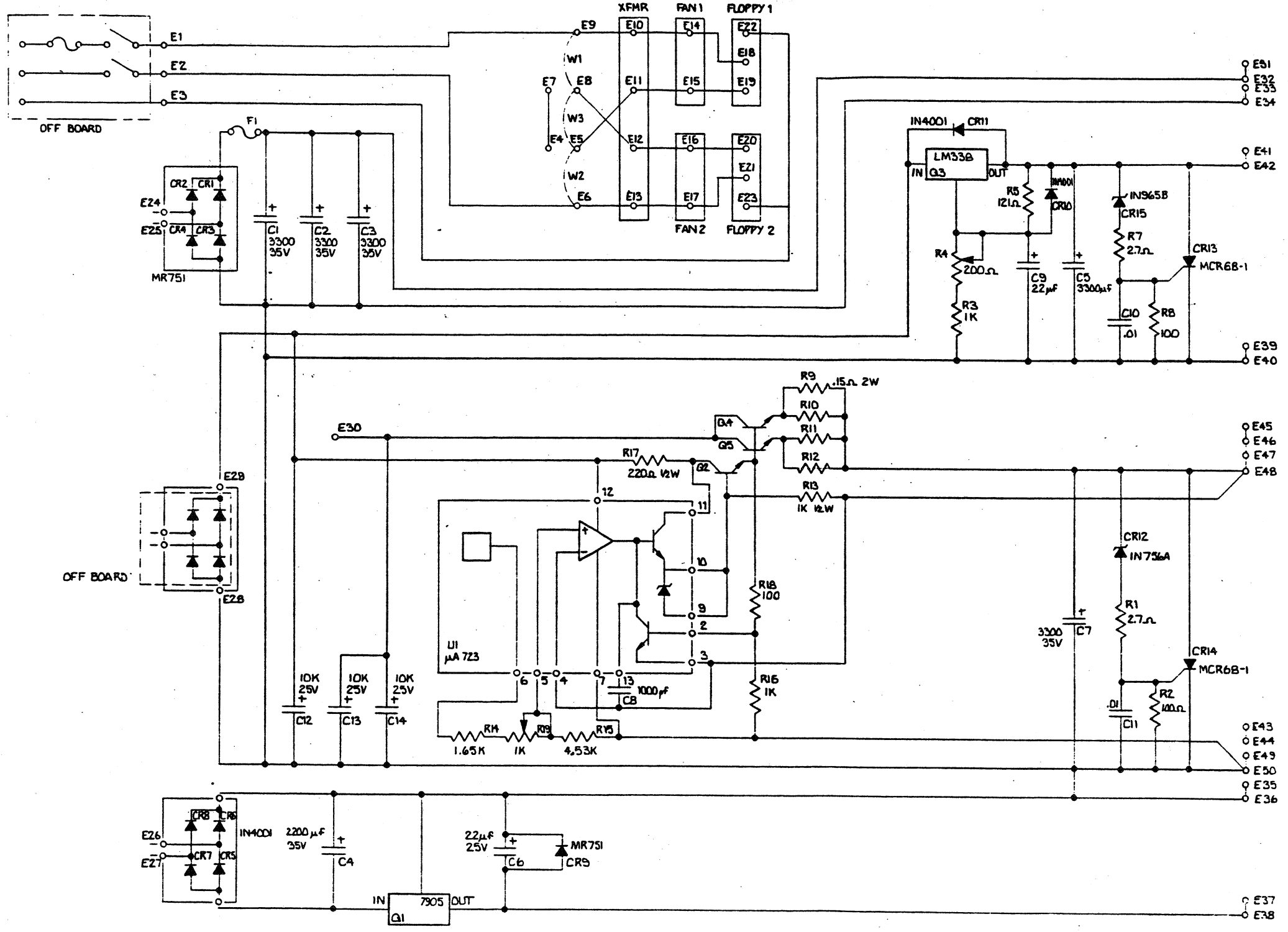

A-1

| | | | | | |
|---|---------|---|----------|--|-----------------------------|
| UNLESS OTHERWISE SPECIFIED DIMENSIONS ARE IN INCHES TOLERANCES ARE: FRACTIONS DECIMALS ANGLES .1 .04 .1 .020 .0150 .005 .010 | | THIS DRAWING CONTAINS INFORMATION PROPRIETARY TO SIGMA INFORMATION SYS- TEMS, INC. AND MAY NOT BE REPRODUCED OR USED FOR OTHER THAN MAINTENANCE PURPOSES WITHOUT PRIOR WRITTEN PERMIS- SION FROM AN OFFICER OF THE ABOVE FIRM. | | Sigma Information Systems Inc. TITLE SCHEMATIC DIAGRAM - PS-00 POWER SUPPLY BOARD | |
| MATERIAL | FINISH | DRAWN <i>[Signature]</i> | 9-2-82 | SIZE D | CODE IDENT. NO. SD400235 |
| NEXT ASSY. | USED BY | ENGINEER | APPROVED | SCALE NONE | WORK ORDER NO. |
| APPLICATION | | DO NOT SCALE DRAWING | | SHEET 1 OF 1 | |